

"SMX"- square cased mixed flow fan



- *Quality range mixed flow fan for commercial/industrial use*
- *5 sizes - casings from 450mm to 700mm square*
- *Airflow to 4m³/sec*
- *Pressure to 500Pa*
- *Single Phase - largest size Three Phase*
- *4 Pole Motors*
- *Speed Controllable*
- *Full range of accessories*

GENERAL

- For industrial and commercial installations.
- High performance rates combined with low noise level
- Airflow to 4.12 m³/sec.
- Speed controllable using auto-transformer.
- External rotor motors for reliability, quality and performance
- Flanged connection for quick and simple installation
- Unique, integral terminal box allows for electrical connections on two sides of casing to ensure flexibility during installation

SPECIFICATION

- Robust construction with casing in 1mm thick galvanised sheet steel
- Motor is external rotor type, single or 3 phase, fitted with thermal overload protection to prevent overheating
- Integral motor/impeller assembly with impeller in polyamide for sizes 350-450 or aluminium for sizes 500 and 560
- Suitable for operation in air temperatures between -10°C and +60°C
- IP54 protection

COMPLY WITH

- Manufactured to ISO9001 in the UK
- EC Low Voltage Directive 73/23-93/68?
- EC Directive EMC89/336?

TYPICAL SPECIFICATION

Supply and install an SMX404M , 4 pole, single phase square cased, mixed flow fan as supplied by Vectaire Ltd, Lincoln Road, Cressex Business Park, High Wycombe, Bucks, HP12 3RH.

This fan is to be suitable for installation in commercial or industrial premises. It is to be speed controllable using an autotransformer.

The casing should be in 1mm thick galvanised sheet steel, the motor to be of the external rotor type, single phase, fitted with thermal overload protection. The unit should be suitable for operation in air temperatures between -10°C and +60°C and have IP54 protection. Fan should be manufactured in UK to ISO9001.

RANGE

- **SMX354M**
4 pole, single phase
- **SMX404M**
4 pole, single phase
- **SMX454M**
4 pole, single phase
- **SMX504M**
4 pole, single phase
- **SMX564T**
4 pole, three phase



Tel: +44(0)1494 522333
Fax: +44(0)1494 522337

Vectaire Ltd
Lincoln Road, Cressex Business Park
High Wycombe, Buckinghamshire, HP12 3RH

Email: sales@vectaire.co.uk
Web: www.vectaire.co.uk

TECHNICAL CHARACTERISTICS



DIMENSIONS

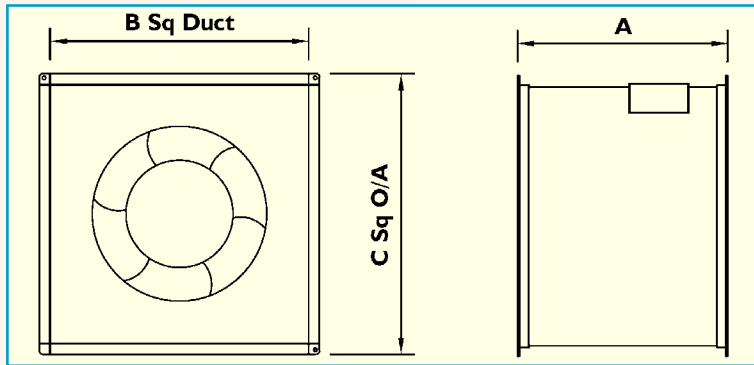

Model	A mm	B mm	C mm	Weight kg
SMX354M	400	450	500	18
SMX404M	435	500	550	26
SMX454M	505	550	620	35
SMX504M	535	661	731	45
SMX564T	570	700	770	54

PERFORMANCE

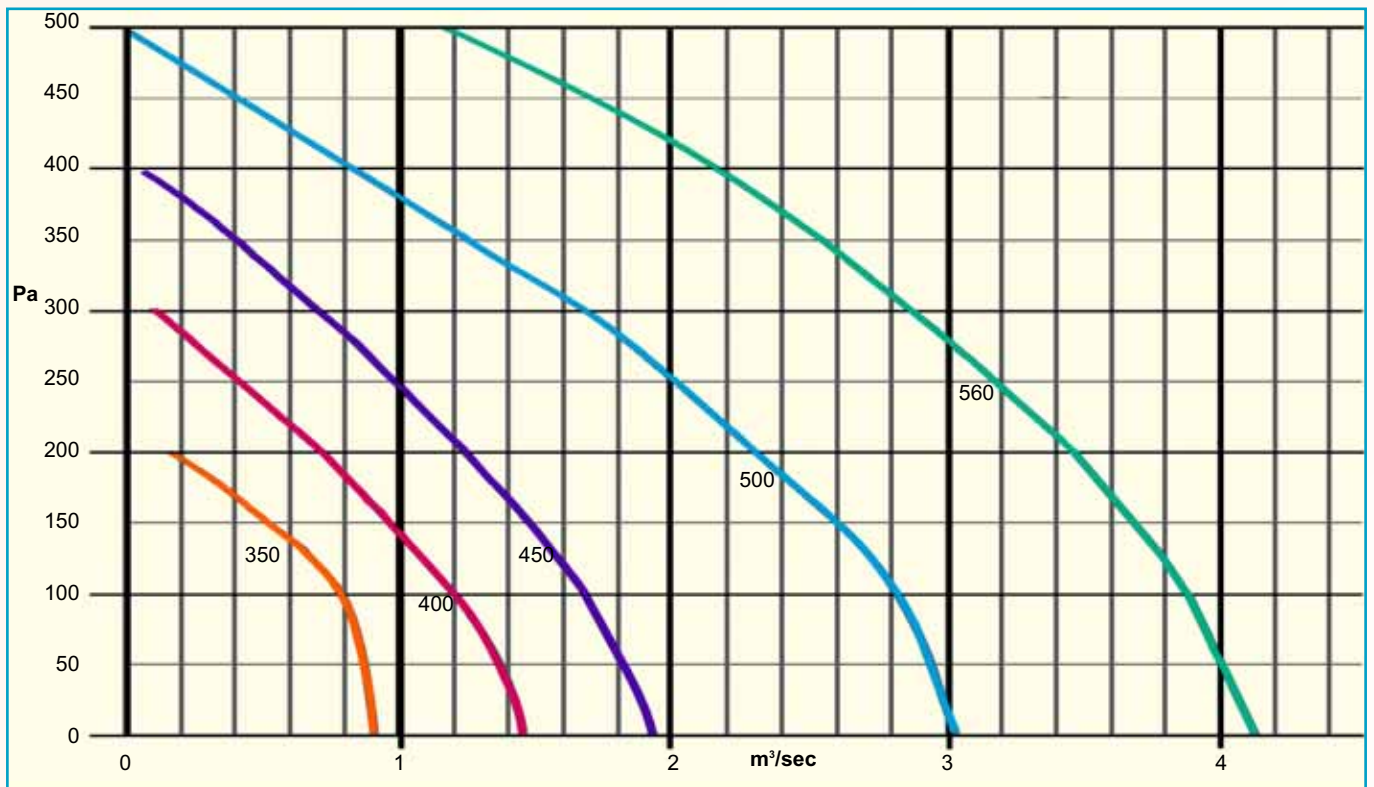

TECHNICAL DATA

Model	Supply	Pole	Power (W)	FLC (A)	SC (A)	dbA @ 3m	R.P.M	Max Airflow		Duty - m³/sec at Pa										Speed Control/Transformer				
								m³/hr	cfm	0	50	100	150	200	250	300	350	400	450		500			
SMX354M	230v,1ph	4	310	1.35	3.7	52	1390	3492	2060	0.97	0.91	0.77	0.53	0.17										VC1AM
SMX404M	230v,1ph	4	520	2.0	5.5	55	1280	5184	3059	1.44	1.37	1.21	0.98	0.68	0.39	0.12								VC4AM
SMX454M	230v,1ph	4	960	4.3	9.6	57	1260	6984	4121	1.94	1.85	1.7	1.48	1.26	1	0.66	0.37	0.1						VC7AM
SMX504M	230v,1ph	4	1450	6.1	15.1	60	1310	10909	6436	3.03	2.92	2.79	2.57	2.31	2	1.65	1.23	0.84	0.5	0.18				VC7AM
SMX564T	415v,3ph	4	2400	4.3	22.0	68	1350	14832	8751	4.12	4.03	3.85	3.65	3.4	3.19	2.88	2.58	2.15	1.67	1.26				VC7AT

SOUND DATA

Model	In duct sound power levels db ref 10 ⁻¹² watts - mid octave bands (Hz)							
	63	125	250	500	1,000	2,000	4,000	8,000
SMX354M	70	74	76	72	72	70	62	54
SMX404M	71	78	79	75	74	69	68	59
SMX454M	80	82	79	76	78	73	68	60
SMX504M	83	85	81	79	80	76	71	66
SMX564T	86	90	87	86	87	81	74	69



ACCESSORIES

Speed Controller/Transformers

A range of autotransformers/speed controllers for 1 and 3 phase models

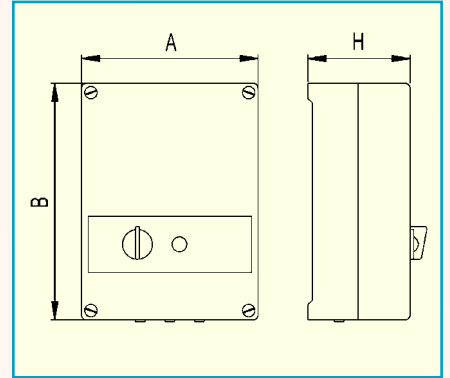
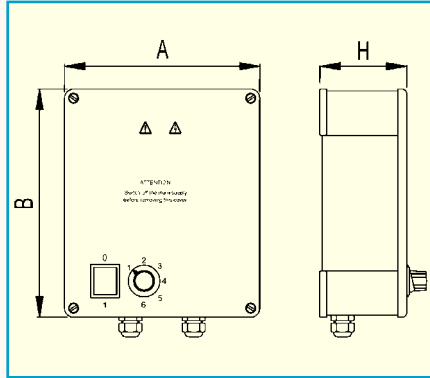

Model	A mm	B mm	H mm	Weight kg
VC1AM	142	166	66	2.5
VC4AM	216	252	96	5.0
VC7AM	262	312	126	8.3
VC7AT	253	316	143	20.0

Silencers

available for all sizes in 1000mm lengths as standard - other lengths available on request.

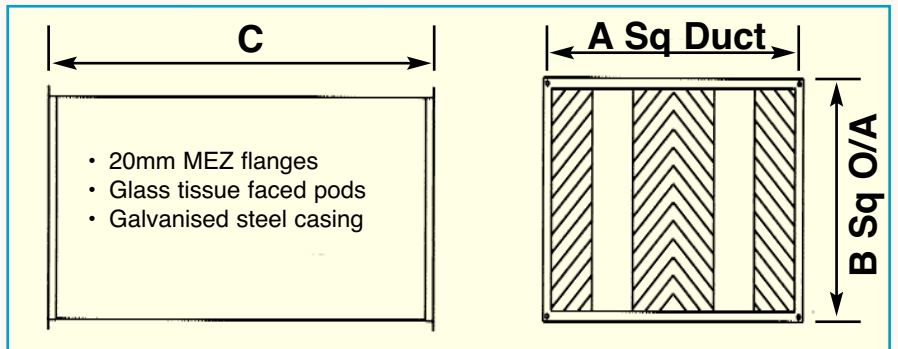

Model	Attenuation: Insertion loss - db - mid frequency Hz								Model	A mm	B mm	C mm
	63	125	250	500	1000	2000	4000	8000				
SMX350SIL	6	11	19	34	45	45	39	28	SMX350SIL	450	500	1000
SMX400SIL	5	9	16	30	39	39	31	26	SMX400SIL	500	550	1000
SMX450SIL	4	7	13	25	32	32	23	15	SMX450SIL	550	620	1000
SMX500SIL	4	7	13	25	32	32	23	15	SMX500SIL	661	731	1000
SMX560SIL	3	6	11	20	25	25	15	8	SMX560SIL	700	770	1000

Flexible Connectors

fitted with proprietary flange at each end to suit ductwork/fan. These are custom built for each size of fan and are 100mm in length.

